

Cut Length Tolerances for Solid Rubber Extrusions

LENGTH IN INCHES ABOVE - INCLUDED	ALLOWABLE TOLERANCE
0.0 - 4.0	+/- .080
4.0 - 6.3	+/- .100
6.3 - 10.0	+/- .125
10.0 - 16.0	+/- .150
16.0 - 25.0	+/- .200
25.0 - 40.0	+/- .250

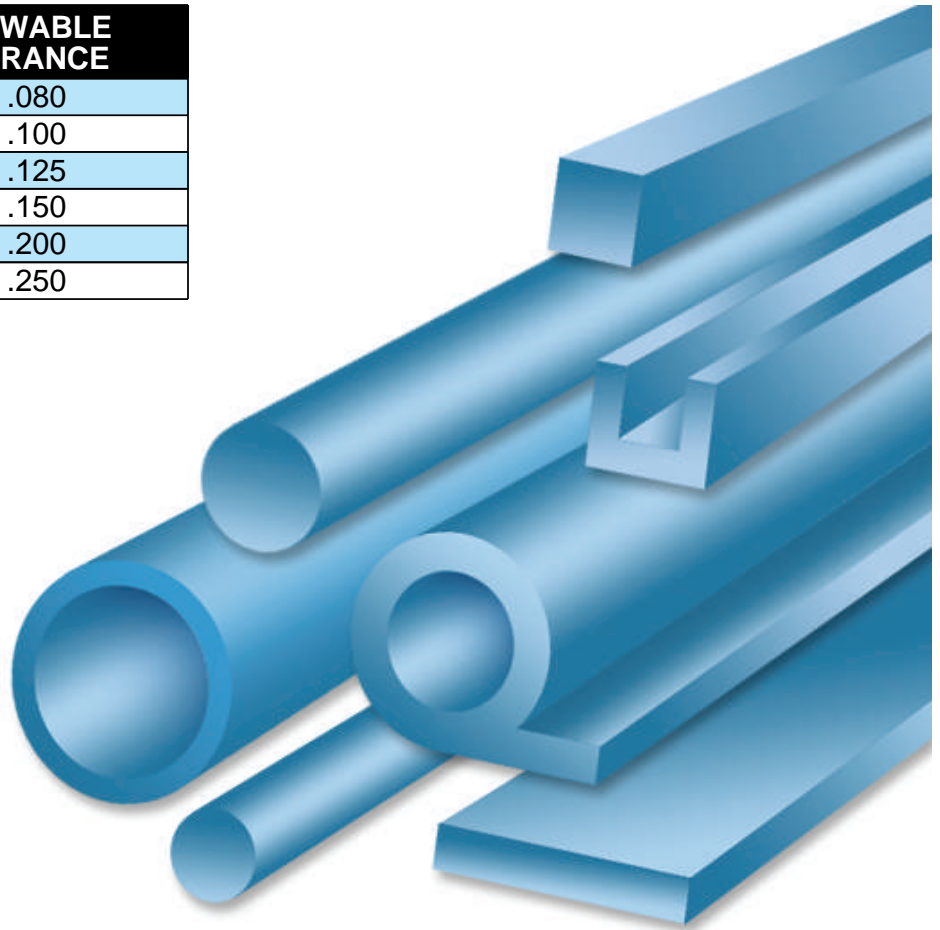

Disclaimer: The information contained in this document is to be used as a guide only. RubberMill cannot guarantee the accuracy, or be held responsible for the information's end use.

Talk to a Person, Not a Machine! · 336-622-1680 · www.RubberMill.com